

AURORA'S

PLACE IN THE SUN

Aurora Q1's record-breaking
Transcontinental Solar
Challenge

TEXT BY PIP SMITH
WITH AMANDA BURDON
PHOTOGRAPHY BY PIP SMITH



AURORA Q1 was zipping along with Dick Smith at the wheel when disaster struck near the South Australia–New South Wales border. Just 65 kilometres west of Broken Hill, the solar vehicle's rear left axle snapped, the wheel locked and Dick slewed off the road. I watched in horror from a support vehicle travelling behind as the sleek solar-powered car skidded off the Barrier Highway and careered, barely under control, into a gravel ditch. Seconds later, a huge, oncoming road train thundered past.

"Get me out, get me out!" Dick yelled over the radio. Afforded only limited vision by the vehicle's tiny bubble canopy, he couldn't see what was going on around him. To make matters worse, he was trapped beneath the vehicle's 80-kilogram top and could smell something burning. In the frantic minutes that followed, I joined other support crew in the race to free him.

"I heard a huge bang and hit the brakes," Dick told me later, shaken. "I thought there'd been an electrical explosion and I wanted to get out – fast."

On inspecting the damage, the Aurora crew discovered that the broken axle had thrown the drive chain, jamming the wheel up against the chassis. What Dick had smelt wasn't an electrical fault, but a hot tyre. Fortunately there was no serious damage and 45 minutes later, its axle repaired, *Aurora Q1* was off again.

The incident could have spelt the end of last year's 4057 km Australian Geographic Transcontinental Solar Challenge from Perth to Sydney. Instead, it proved a valuable learning experience, albeit a scary one.



Solar success. A large crowd greets Dick Smith (opposite) at the steps of the Sydney Opera House as he completes *AURORA Q1*'s 4057 km trans-Australia crossing. Dick was one of six drivers during the eight-day Australian Geographic Transcontinental Solar Challenge whose view of the passing countryside was restricted by a tiny, blister-like bubble canopy (above). The solar vehicle (below) followed major roads, and although it performed well, difficult weather and varying road conditions tested its mettle.



LEADING LIGHT IN SOLAR TECHNOLOGY

AURORA Q1 – Australia's most sophisticated solar car – is the brainchild of some of our brightest automotive engineers and scientists. Refinements are likely to continue well into the next century and already several of the vehicle's innovative features have been patented.

Aurora Q1 is a tricycle built on a **triangular, aluminium chassis** incorporating **coil-spring suspension** and an envelope-shaped aerodynamic body. Each **spoked wheel** carries a similar weight, ensuring stability and safe handling, and **wheel fairings** help reduce wind resistance.

Reclining snugly in a central **cockpit** in which the instruments are fixed to a "dashboard" arm, the driver is screened from the elements by an acrylic **bubble canopy**. The front wheel is steered with a simple **handlebar** fitted with a motorcycle-style brake lever operating a single front disc brake. The vehicle also has a cable-operated, rear emergency brake.

Its electronic nerve centre was designed by Stuart Watkinson of Australian Energy Research Laboratories and engineers from Melbourne University's electrical and electronics engineering department. In ideal conditions, electricity flows directly



Power came from the sun via an 80 kg removable solar array being fitted over co-driver Viv Baddeley (above) before a shift behind the wheel on the Nullarbor Plain. Ahead stretched three hours of cramped, humid driving reclined in the cockpit 70 cm above the ground.

from the solar array to the direct-current **electric motor**. However, if sunshine is inadequate or the vehicle is travelling uphill, the motor draws from surplus electricity stored in lead-acid and lithium-thionol **batteries**, mounted in the nose to keep the centre of gravity well forward.

Electricity from the solar array is regulated by devices called **maximisers**, which continually adjust to changes in conditions to ensure that the maximum possible power is delivered. The **motor controller** unit regulates the voltage and current from the batteries to the motor.

Aurora Q1's crowning glory – a total of 1943 **solar cells** arrayed on its sleek, curved upper skin – was made at the University of New South Wales Centre for Photovoltaic Devices and Systems. They're among the most efficient in the world – and together produce 1.4 kW in full sun. But it's the way they're mounted – overlapped to leave no gaps between them and to ensure that the entire surface is covered – that helps give the vehicle its competitive edge. A smooth, clear epoxy-resin skin helps reduce air resistance.

Amanda Burdon



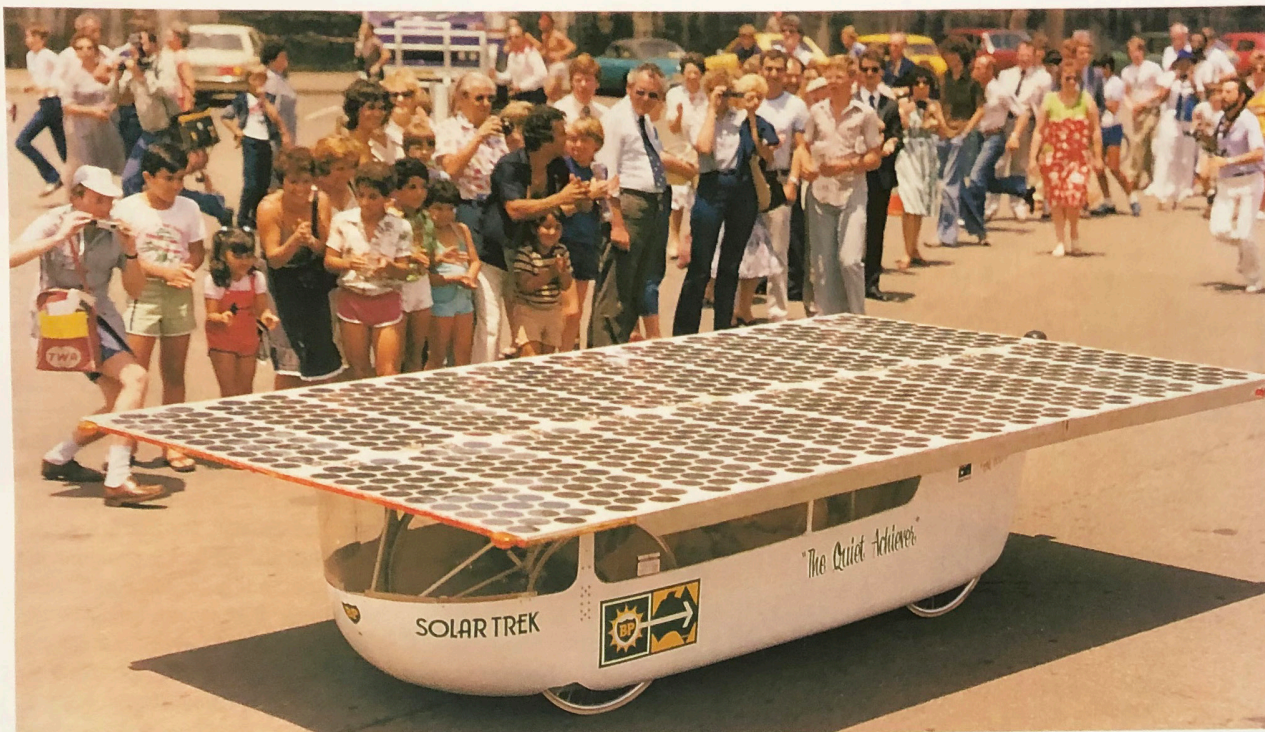

The AURORA Q1 team was chasing a record set in 1982–83 by Hans Tholstrup and Larry Perkins, who crossed Australia in 20 days in THE QUIET ACHIEVER (above), the world's first solar vehicle. Hans (right), demonstrating his culinary skills with Dick on day three came along as official observer and cook. He too hailed the challenge as a great success.

I've become accustomed to Dick's daring adventures throughout our marriage, so it came as no surprise when he'd challenged the Aurora team to break the trans-Australia record set in 1982–83 by Hans Tholstrup and Larry Perkins in the solar car *The Quiet Achiever*. In the 12 years since that historic journey there had been remarkable advances in solar technology and the *Aurora Q1* team was confident it could halve the 20-day record.

In 1993, helped by Australian Geographic Society sponsorship, the Australian-designed and built *Aurora Q1* came fifth in the highly competitive World Solar Challenge from Darwin to Adelaide. With the race over, it took little for Dick to persuade the team's then manager Viv Baddeley to agree to tackle the Perth to Sydney crossing. Ian Cole, who replaced him, was to put the finishing touches to the plans.

The challenge also brought Dick together with his long-time friend Hans Tholstrup. They'd first shared the joys of solar-car racing in 1987 when Hans organised the first World Solar Challenge, in which the AG-sponsored Team Marsupial vehicle (AG 11) competed. This time round, Hans joined us as official scrutineer and camp cook for the 15-strong *Aurora* team – a far cry from *The Quiet Achiever's* support crew of just four.

Another key difference, of course, was the vehicle itself. At just 1 metre high, 4.4 m long and 2 m wide, and weighing 220 kg (without driver), the three-wheeled



AURORA Q1 turned heads and attracted attention wherever it went. At Coolgardie, south-west of Kalgoorlie in WA, driver Caroline Bommer (above), a Sydney mechanical engineer and patents lawyer, holds court with a television crew.



Making the most of every available ray of sunshine was a full-time occupation. At Ceduna, Peter Pudney and Kendrick Pavey (top) position the solar array on a special stand to catch the last light of the sun and charge batteries while Viv Baddeley checks the circuitry beneath. The car's sleek, aerodynamic lines thrilled Karcultaby Area School's students (above), who got wind of its approach on their CB radio and hurried to line the Eyre Highway and watch it whiz by.

Aurora Q1 is compact and much more advanced than the earlier vehicle (see page 80). A total of 1943 solar cells, a combination of two types of photovoltaic cells designed by the University of New South Wales (*Pyramids of the Sun*, AG 38), power a 2-kilowatt electric motor. Any surplus electricity is stored in batteries. But it was the vehicle's aerodynamic shape that turned heads when we gathered in Perth for the start of the event on 31 October last year.

"How does the driver breathe?" asked Perth student Dannielle Finnerty. Team member Kendrick Pavey pointed to a plastic tube near the driver's face and explained that air was drawn into the car as it moved. "It must get very hot inside," another little voice chimed. "It is very hot," said Stuart Wilson, one of the team's six co-drivers. "But we're happy when it's sunny because sunlight caught by these solar cells," he said, pointing to the shimmering panels on top, "powers the car."

"It looks like it's from outer space," Dannielle's classmate Hannah Packwood said. But the team was preoccupied with more earthly tasks as Dick buckled up in the driver's seat and prepared to set off. Cheered by the crowd, Western Australia's Minister for Resources Development and Energy Colin Barnett dropped the starting flag and, escorted by police, *Aurora Q1* began its journey through Perth's streets.

I followed in one of our five support vehicles. In the lead car were the team's three strategists, including Peter Pudney, a senior research fellow in mathematics at the University of South Australia. They used complex mathematical models on a computer to predict car performance, weather conditions and battery energy, and to advise on the best driving speed.

"The strategists calculate how best to manage the batteries to make the most of the sun's energy," Peter told me.

The importance of strategy became apparent as we drove across WA, over the undulations of the Great Eastern and Eyre highways. Although clouds chased us eastward, the vehicle performed well, averaging 46.8 km/h.

We'd travel from dawn to dusk, stopping every few hours to change drivers. And when the afternoon shadows lengthened, we'd set up camp and harness the day's remaining sunlight to recharge the batteries, which were also boosted by the first light of morning. *Aurora Q1's* chassis was also thoroughly serviced and cleaned at day's end as part of a well-drilled mechanical check.

"Solar cars are our lives," team member Greg Locock told me one night over dinner. "You get a powerful feeling of achievement to see something that you've helped design and build perform so well."

Having perfected our daily routine, the kilometres soon sped by, with *Aurora Q1* often cruising along at up to 85 km/h. Avoiding live and dead kangaroos kept the drivers on their toes, and we were surprised by the variety of wildlife we saw – including eagles, emus, wild pigs and shingle-back lizards. Bright-yellow and mauve wild flowers formed a colourful roadside carpet.

The magnificent gum trees and wheat fields of WA gradually gave way to the flat, treeless Nullarbor Plain, and by the end of the fourth day we'd crossed into South Australia, skirted the Great Australian Bight and been the object of much curiosity at a fruit-fly checkpoint.

How sweet it is. After 8.5 arduous days, AURORA Q1 team members Mark Burns, Stuart Wilson and Tony Vriens savour their record-breaking success at the Sydney Opera House. The 15-strong team slashed the record by more than 11 days, in a convincing demonstration of the incredible advances in solar technology being pioneered by Australians. Harking back to the 1982–83 crossing, at journey's end the AURORA Q1 team poured water brought from the Indian Ocean into Sydney Harbour, an inlet of the Pacific – a gesture that symbolised the bridging of a continent.



TONY GORDON

Early next day, we rounded a corner on a lonely stretch of the Eyre Highway to be met by a heart-warming scene – all the 140 students of Karcultaby Area School, near Poochera, west of Port Augusta. If only they could have seen the vehicle in action a few hours later when it steadily climbed the foothills of the Flinders Ranges! Kendrick and Michael Hofmann had changed the gearing and I watched in wonder as the tiny vehicle inched its way up the hills at a steady 13 km/h. Even with the clouds threatening on that fifth day, *Aurora Q1* managed 554.4 km – reaching Willowie, east of Port Augusta, at nightfall.

It was in sheep country, nearing the South Australia–New South Wales border on the sixth day of the challenge that the vehicle's left axle broke. But any anxiety the mishap caused was forgotten when we crossed the border and arrived in Broken Hill. Well-wishers bearing homemade signs lined the streets and *Aurora Q1* was honoured with an official welcome from Mayor Peter Black.

The welcome was equally warm later that day, another four hours west, when we arrived at probably our most unusual camp site – the prisoners' exercise yard at Wilcannia police station. Senior Sergeant John Tallis kindly accommodated us and, exhausted, I slept soundly in my swag.

By the end of the seventh day, after being blown along with the dust from drought-affected paddocks around Nyngan, *Aurora Q1* sped into Dubbo. Buffeted by strong, erratic winds and shadowed by cloudy skies, the question on everyone's lips was whether it would be able to climb 380 m Victoria Pass – the western approach to the Blue Mountains and one of Australia's steepest highway grades – our biggest obstacle. Ian Cochrane, a lecturer in electrical engineering at Melbourne University, had joined us in Broken Hill for the task and Stuart was in the hot seat.

"Get the speed up at the bottom," Ian advised him over the radio. "Then use as much power from the batteries as you need."

"No problem," Stuart replied confidently. "I'm doing

40 km/h with 1.5 amps to spare." As *Aurora Q1* neared the top of the climb, Stuart's enthusiasm crackled through the radio. "Fantastic. We just have to roll down from Katoomba into Sydney and we've done it!" Cheers rang out across the surrounding countryside as *Aurora Q1* topped the crest.

And Stuart was right – it was very much downhill from there. On the final day – 8 November – 8.5 days after we'd started, Dick had the honour of driving *Aurora Q1* to the Sydney Opera House, where a crowd of well-wishers had assembled, appropriately, in glorious sunshine. We'd slashed the record by more than 11 days and as the vehicle's solar top was lifted, Dick triumphantly waved the Australian flag.

"We've shown how far solar technology has come and hopefully people will one day have electric cars assisted by solar technology," Dick said. "I'm hopeful that they'll also be a lot more comfortable than this one!"

As for the Aurora team, there are many more adventures in store as they plan their assault on the 1996 World Solar Challenge and attempt to raise \$5 million for their bid. But like Hans, they heralded the transcontinental challenge as a great triumph.

"We've made incredible progress in just 12 years," Hans told me. "If we can continue to make these strides there's a chance the world can sustain itself on renewable energy."

Having seen *Aurora Q1* in action, I've no doubt that solar power is one of the brightest rays of hope for the future.



AUSTRALIAN GEOGRAPHIC thanks Optus, WA and NSW Police Traffic Services, Wilcannia police, Michelle and Bently Foulis, Willowie Memorial Hall, Flag Motor Inns at Ceduna and Dubbo, and Keith and Barbara Carstairs of the Alpine Motor Inn, Katoomba. *Aurora Q1* thanks its major sponsors, AUSTRALIAN GEOGRAPHIC, Ford Australia, Plexicor, Bosch/Blaupunkt, IRH, PrixCar/Finemores, Sumitomo Corporation, Viscount Industries and Optus, with additional support from the CSIRO, CIBA, Phillips, Michelin, GE Plastics and the RACV.

The vehicle's **solar cells** are overlapped to eliminate gaps and ensure that every available centimetre produces electricity and the solar array is coated with a clear epoxy resin. Cell terminals are beneath the solar panel for easy access.

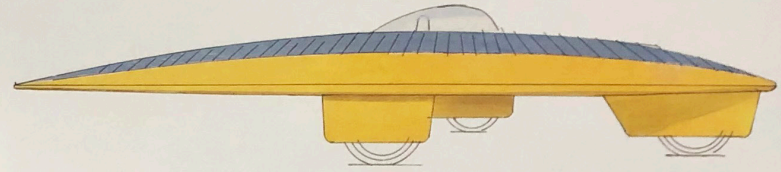
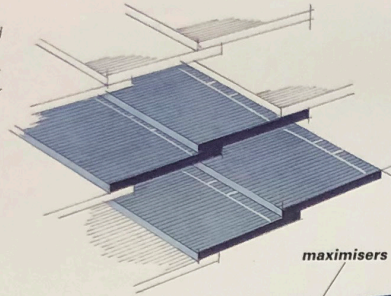

Aerodynamics and solar array power were the two overriding design considerations for AURORA Q1. Wheel fairings and a streamlined, tapered body help reduce wind drag.

bubble canopy

maximisers

cockpit

batteries

wheel fairings

electric motor

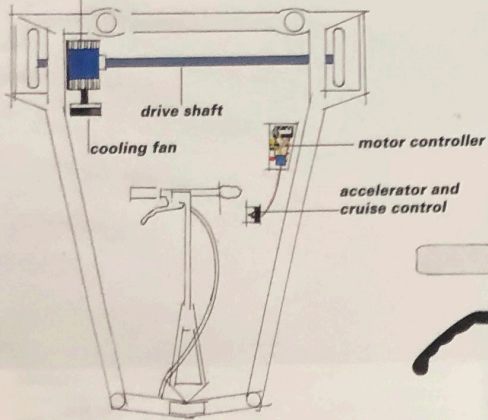

drive shaft

cooling fan

motor controller

accelerator and cruise control

A compact, rigid, **aluminium chassis** enables other components to be packed neatly inside the car. The motor drives only the left rear wheel, via a lightweight propeller shaft. Wired to the motor controller unit, and operated by the driver's left hand, are acceleration and cruise controls.

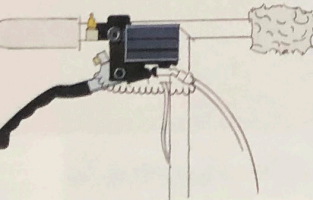

The **handlebar** is fitted with a lever that operates the front brake and a switch for the radio headset. The handlebar lifts out of the cockpit to make it easier to get in and out of the car.

coil-spring suspension

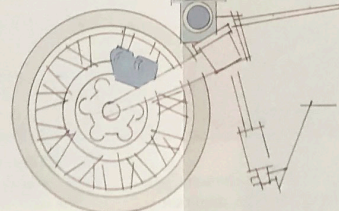

The single, **spoked front wheel**, fitted with a disc brake, is steered by a handlebar. Each of the vehicle's three 50 cm wheels has an aluminium rim, custom-made hub and a racing tyre.

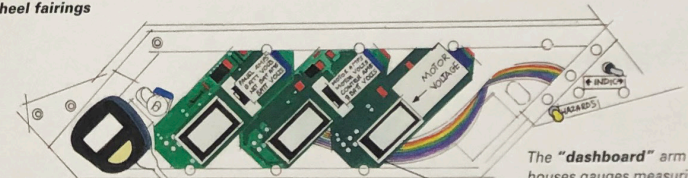

Standard bicycle **speedometer/odometer**.

Motor controller meter - indicates the controller's current, the battery voltage, and the motor's voltage and current.

Solar array/battery meter - measures and displays the solar panel's current and voltage, battery voltage and net battery current.

Motor voltage digital display. Because the motor voltage is proportional to speed, this gauge doubles as a speedometer.

The "dashboard" arm houses gauges measuring speed, voltage and current. Switches for the hazard lights, indicators and the driver's fan are on the right-hand side.

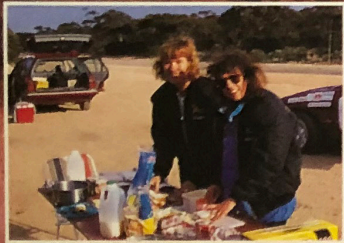

Climbing Victoria Pass (inset, top left) – one of Australia's steepest highway grades – was AURORA Q1's greatest challenge, demanding careful planning by the team's three strategists. Equally vital to the record bid were the caterers, including Pip Smith and Caroline Bommer (middle left), pictured preparing lunch beside the Eyre Highway, 25 km west of Balladonia. Despite the remoteness and often difficult driving conditions, there were no serious mechanical mishaps – apart from a broken rear axle (bottom left) west of Broken Hill.

It could have spelt the end of the challenge, but the well-drilled team quickly swung into action and had the vehicle back on the road in 45 minutes.

As the sun sets on another day (above), camp preparations begin near Mundrabilla, as the team approaches the WA-SA border. An average of 470 km was travelled each day, with AURORA Q1 often

on the road from dawn until dusk, and the pace didn't slacken after dark. Every evening the vehicle was thoroughly overhauled and any necessary repairs made before the next day's strategies were discussed. The convoy that accompanied AURORA Q1 consisted of five support vehicles, including a car towing a well-equipped trailer that doubled as a mobile garage.

PETER PLUMLEY